

FLASHING, WEEP HOLES AND RELATED ANCHORAGE

Proper flashing and weep holes are essential elements of masonry construction. Together, they provide a means to control moisture in a wall. If not addressed, moisture can have damaging effects on exterior walls, such as crazing, efflorescence and spalling. Improper flashing can also lead to moisture in the interior of a building. An effective system to deal with exterior moisture penetration is necessary for a properly functioning cast stone wall.

A drainage wall, also known as a cavity wall, is the most effective solution for a cast stone wall exposed to the elements.

THE DRAINAGE WALL

A drainage wall has five essential elements.

- Exterior wythe of masonry
- A clear cavity or air space of at least 1 inch
- An interior wythe of masonry or other backing material
- Flashing at all interruptions in the drainage cavity
- Properly spaced weep holes at all flashing locations.

The exterior wythe provides first line of defense against moisture penetration. Cast stone should be laid with full joints in mortar meeting the requirements of ASTM C 270, Type N mortar. (See [Technical Bulletin #42](#).) Care should be taken when laying the stone to ensure the cavity behind this wythe stays clear. A tapered bed joint can help minimize mortar droppings and protrusions into the drainage cavity. A minimum 1 in. cavity or air space is recommended. Cavities of 2 in. or more are easier to keep clear of mortar and debris. Cavities over 4 in. may require special ties and anchors. When insulation is specified, the space of the cavity is measured from the outer face of the insulation to the back of the exterior wythe. (See Technical Detail 4.)

Through-wall flashing and weep holes should be used at the base of the drainage wall and at all interruptions in the cavity, such as at window heads and relieving angles. Flashing must be continuous and properly lapped and sealed at the base of the wall and at relieving angles. When flashing is used over openings, such as at windows, end dams are required. (See Technical Detail 1.) Weep holes allow collected water to be directed from the drainage cavity to the outside. Head joints with an opening of 1 in. in height are recommended as they provide the best drainage. They should be spaced no more than 24 in. apart. Rope wicks can also be used, but weep holes should be placed closer together, at 16 in. o.c., since this type does not drain as quickly. Plastic tubes are not recommended because they are easily clogged by mortar or by insects. In stones over 24 in. in length, a 3/8 in. wide by 1 in. high notch through the base of the stone is recommended for drainage. Unnecessarily long lengths of stone are discouraged because adequate drainage between weep holes can be a problem. Moisture retained in the wall can lead to crazing of the Cast Stone.

FLASHING AT BASES

Flashing and weep holes must be used at the base of a cavity wall and at all horizontal obstructions. Flashing should extend from the exterior face of the cast stone wythe into the cavity. For self-adhered flashing, cut back 1/2" from the face of the cast stone to prevent bleeding of the rubberized asphalt. In the case of a masonry backing wythe, the flashing should be turned up a minimum of 8 in. and extend into the masonry backing. In framed backing walls, the flashing should extend up the cavity at least 8 in. and be attached to the exterior sheathing with a termination bar. Building paper or other water resistant membrane on the interior wythe should overlap the top of the flashing.

Flashing is also recommended below all Cast Stone belt courses and watertables that sit on a relieving angle or occur at a change in material, i.e. stone to brick. In most cases, flashing and weep holes should be placed directly below the Cast Stone course for proper drainage of the cavity. In cases where stone and clay brick are used together in the same wythe, the flashing also serves as a bond break between the Cast Stone and the brick.

Because clay brick undergoes irreversible moisture expansion and Cast Stone, like other cementitious products, tends to shrink, flashing between the different courses allows horizontal movement to occur without cracking the mortar joints or units. The Brick Industry Association's Technical Notes 18 Series provides further information on this topic. Stones must be anchored, top and bottom, to the backing material when this detail is used.

FLASHING OVER OPENINGS

Cast Stone window heads and arched openings also require flashing. If the Cast Stone is supported by a relieving angle, flashing and weep holes are located below the stone course, on the relieving angle. When no relieving angle is used, as in the case of structural stone lintels, flashing should be placed directly above the stone course. In either case, proper anchorage of the stone to the backing is imperative.

FLASHING AT COPING AND CAPS

Experience has shown that Cast Stone coping perform best when the mortar bond with the masonry wall is maintained. For this reason, flashing should not extend over the full width below the Cast Stone coping. Instead, the flashing should be turned down into the drainage cavity and then out through the exterior supporting wythe below. (See Detail Plates 5, 6 & 7) This prevents the potential for water to pond underneath, which can deteriorate the mortar through the freeze-thaw process. In extreme cases, even the cast stone may be damaged due to repeated cycles of freezing and thawing while critically saturated for extended periods of time. This differs from recommendations found in the Brick Industry Associations Technical Notes.

At chimney caps, step flashing from below the Cast Stone coping down through the first course of supporting masonry below the weep holes should be located in the head joints of the first course of supporting masonry. (See Detail 3.)

ANCHOR PENETRATIONS THROUGH FLASHING

The anchors for attaching Cast Stone may be required to penetrate flashing and building paper to allow a secure connection to the structure. Where this occurs, proper steps must be taken to ensure a watertight connection at the interface so that the anchor does not compromise the integrity of the flashing. Grommets, thimbles, sleeves, couplings and sealants are available for this purpose, but it is beyond the scope of this Technical Bulletin to provide specific guidance.

FLASHING MATERIALS

Flashing is a key element in a drainage wall. Poor flashing materials can become brittle over time and may allow water to penetrate the building interior. As a result, longevity and life cycle cost should be considered, in addition to first costs, when choosing a flashing material.

Flashing materials used successfully with Cast Stone include stainless steel, copper, copper laminates, EPDM, and rubberized asphalt. Polyvinyl chloride (PVC) and galvanized steel flashing should be avoided because of their questionable long-term performance. (See the Brick Industry Associations Engineering & Research Digest, “Through-Wall Flashing”, for a detailed discussion.) Table 1 lists some advantages and disadvantages of each flashing material that must be considered in making a final selection.

Table 1: TYPES of FLASHING MATERIAL

Material	Minimum Thickness	Advantages	Disadvantages
Stainless Steel	0.01 in. (0.25 mm)	Extremely durable, non-staining	Difficult to solder and form
Cold Rolled Copper	10 ounces/ft ² (3100 g/m ²)	Durable, easily formed, easily joined	Stains adjacent masonry
EPDM	30 mils (0.8 mm)	Flexible, easy to form, easy to join, non-staining	Metal drip edge required more easily torn
Rubberized Asphalt	40 mils (1.0 mm)	Self-healing, flexible, easy to form, easy to join	Dimensional instability, incompatibility with joint sealant, metal drip edge recommended
Copper Laminates	5 ounces/ft ² (1500 g/m ²)	Easy to from, easy to join, non-staining	Metal drip edge required, more easily torn

Table printed with permission from the Brick Industry Association Engineering & Research Digest, “Through-Wall Flashing”.

Anchoring and Flashing Details

These are typical connections recommended by the Cast Stone Institute for similar applications. Consult your engineer for size and connection requirement before ordering anchors.

DETAIL 1-"Z" STRAP ANCHOR @ HEADER

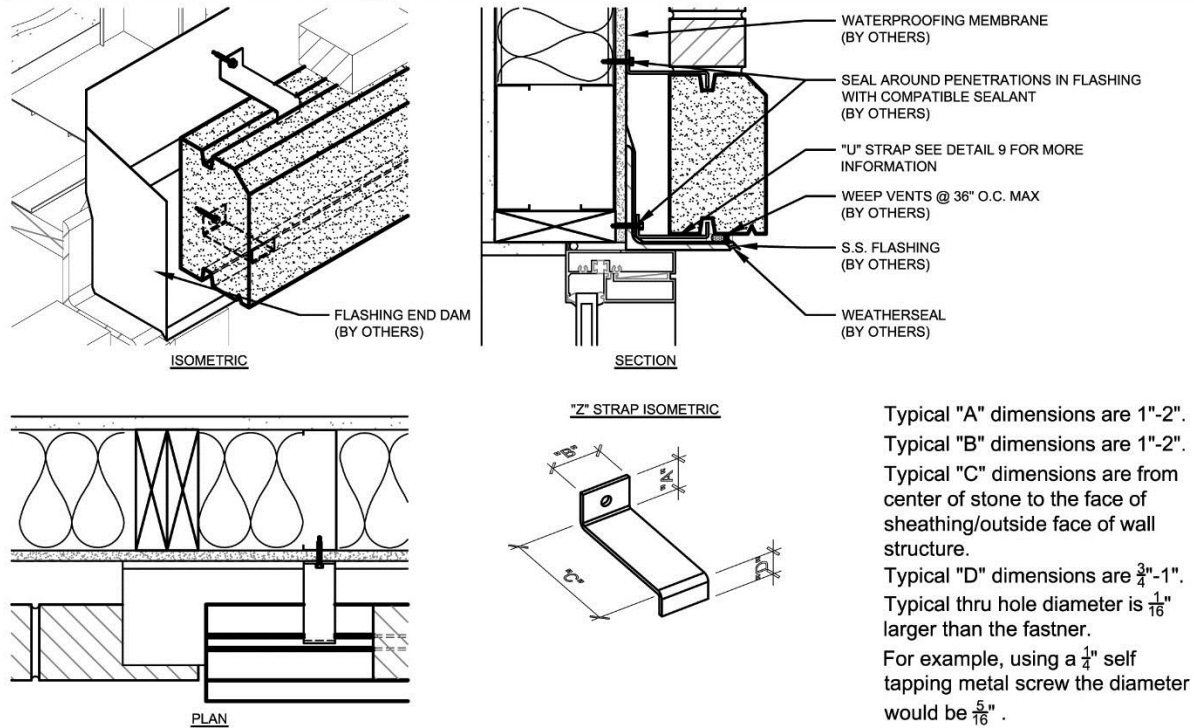

DETAIL 2-"L" STRAP W/ WELDED DOWEL PINS @ JAMB

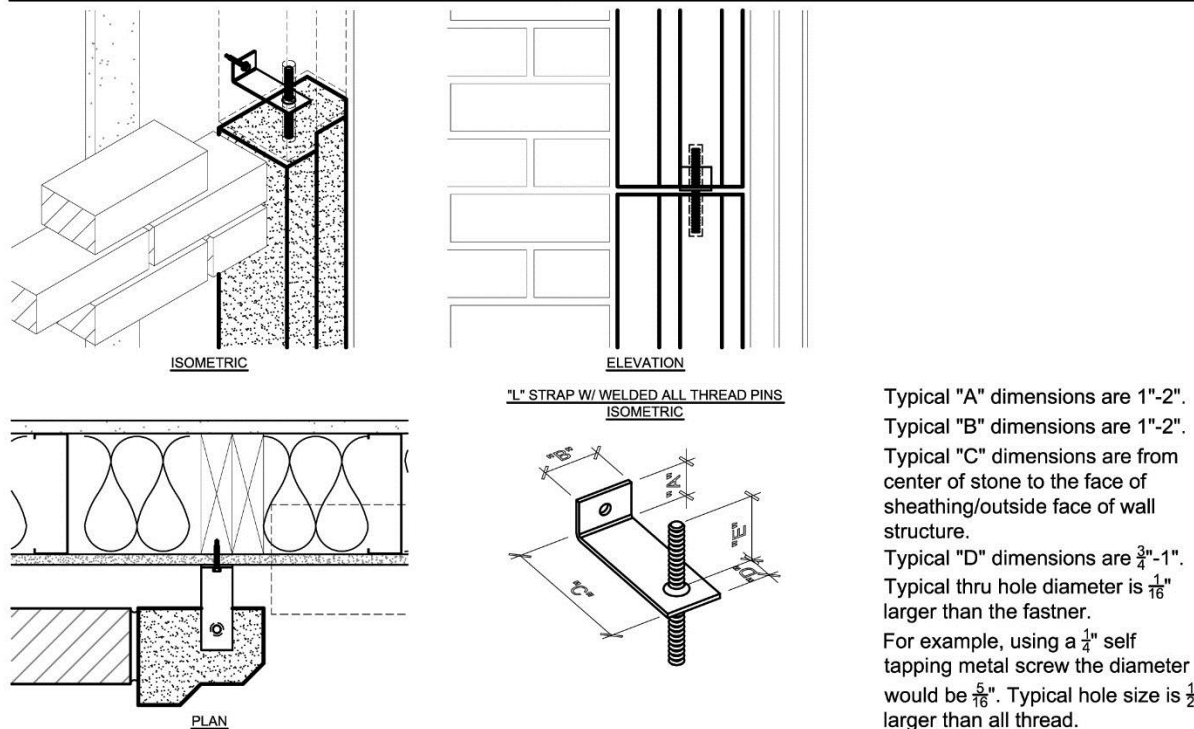

Anchoring and Flashing Details

These are typical connections recommended by the Cast Stone Institute for similar applications. Consult your engineer for size and connection requirement before ordering anchors.

DETAIL 3-"L" STRAP W/ WELDED DOWEL PIN @ SILL

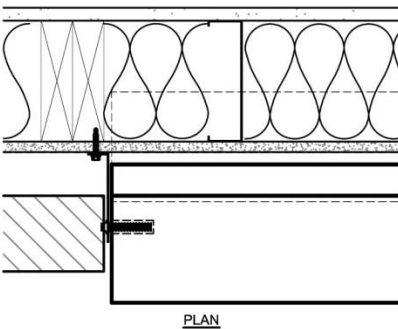
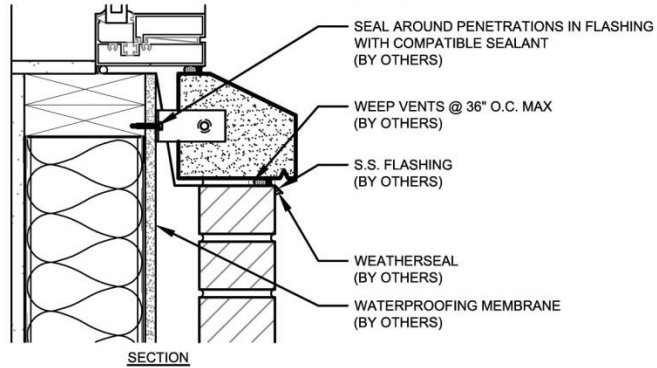
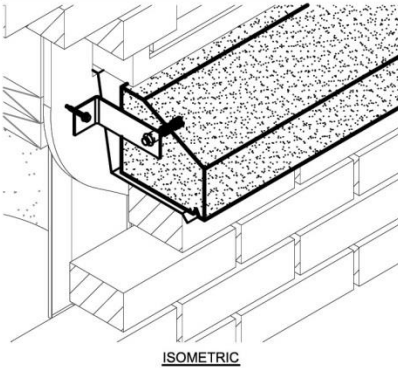

"L" STRAP W/ WELDED ALL THREAD PIN ISOMETRIC

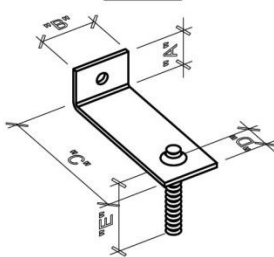

Typical "A" dimensions are 1"-2".
Typical "B" dimensions are 1"-2".
Typical "C" dimensions are from center of stone to the face of sheathing/outside face of wall structure.
Typical "D" dimensions are $\frac{3}{4}$ "-1".
Typical thru hole diameter is $\frac{1}{16}$ " larger than the fastener.
For example, using a $\frac{1}{4}$ " self tapping metal screw the diameter would be $\frac{5}{16}$ ". Typical hole size is $\frac{1}{2}$ " larger than all thread.

DETAIL 4-"SPLIT TAIL" STRAP @ VENEER

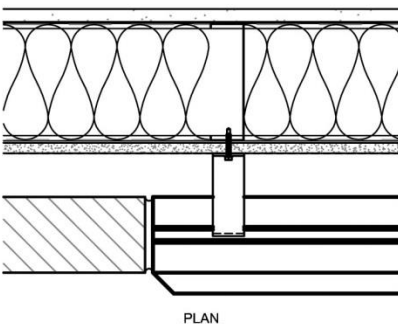
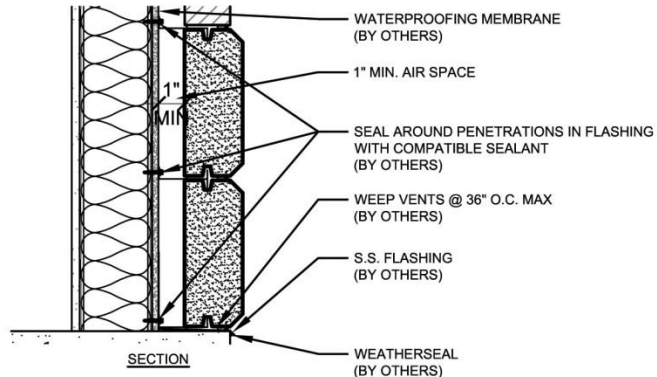
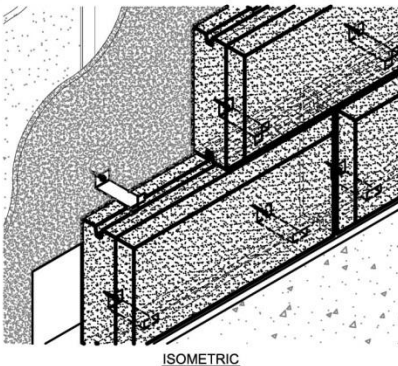

"SPLIT TAIL" STRAP ISOMETRIC

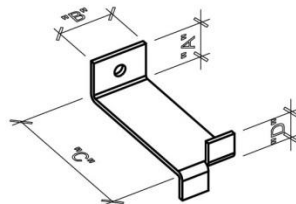

Typical "A" dimensions are 1"-2".
Typical "B" dimensions are 1"-2".
Typical "C" dimensions are from center of stone to the face of sheathing/outside face of wall structure.
Typical "D" dimensions are $\frac{3}{4}$ "-1".
Typical thru hole diameter is $\frac{1}{16}$ " larger than the fastener.
For example, using a $\frac{1}{4}$ " self tapping metal screw the diameter would be $\frac{5}{16}$ ".

Anchoring and Flashing Details

These are typical connections recommended by the Cast Stone Institute for similar applications. Consult your engineer for size and connection requirement before ordering anchors.

DETAIL 5-"L" STRAP W/ WELDED DOWEL PINS @ COPING

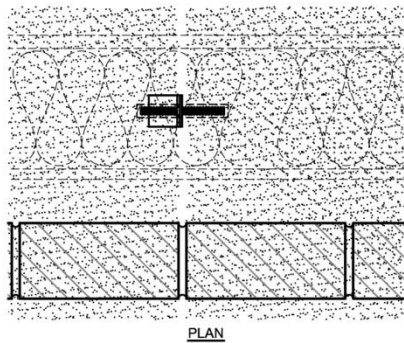
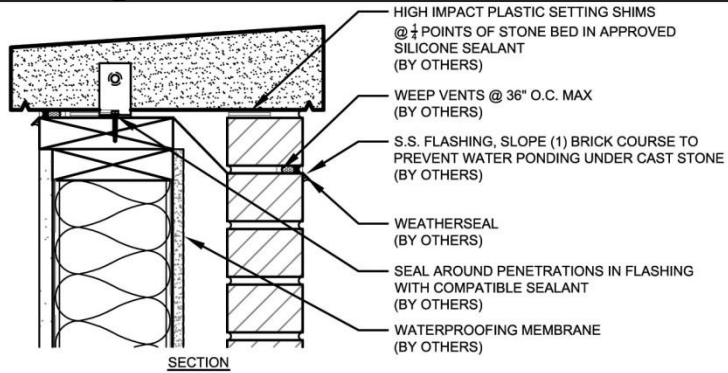
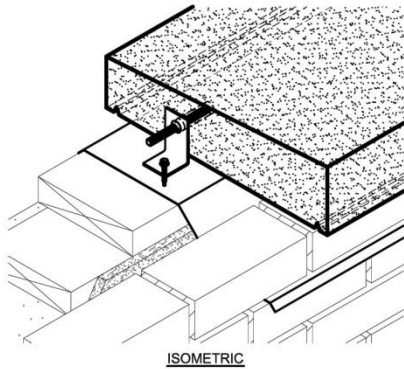

"L" STRAP W/ WELDED ALL THREAD PINS

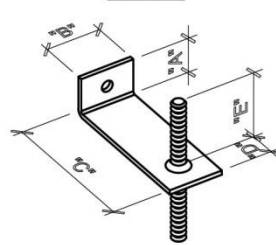

Typical "A" dimensions are 1"-2".
 Typical "B" dimensions are 1"-2".
 Typical "C" dimensions are from center of stone to the face of sheathing/outside face of wall structure.
 Typical "D" dimensions are 3/4"-1".
 Typical thru hole diameter is 1/16" larger than the fastener.
 For example, using a 1/4" self tapping metal screw the diameter would be 5/16". Typical hole size is 1/2" larger than all thread.

DETAIL 6-WELDED DOWEL PIN AND PLATE @ COPING

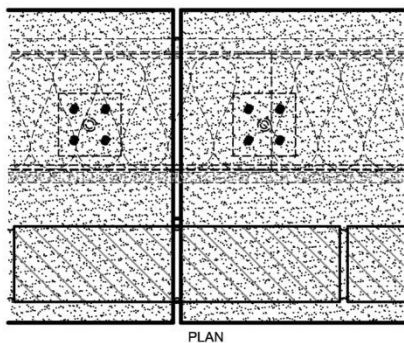
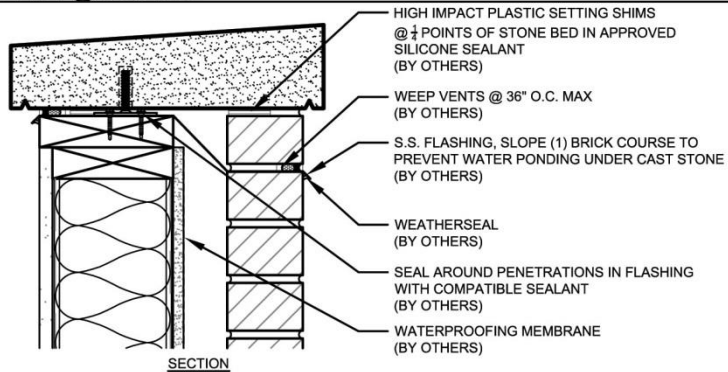
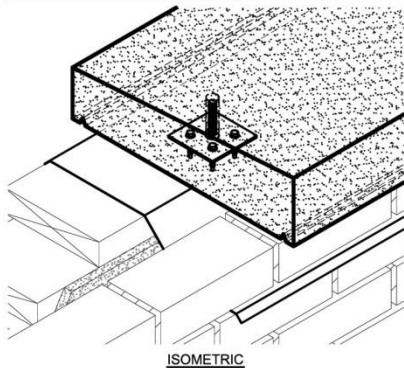

WELDED ALL THREAD PIN AND PLATE

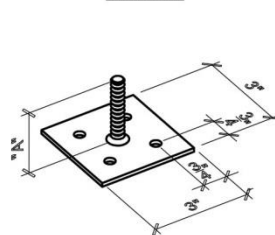

Typical "A" dimensions are 2"-3", with the most common being 2".
 Typical diameter varies from 3/8"-1" depending on the size of the stone. Most commonly used are 1/2" diameter x 2" LG. Field drill 1" diameter x 2" hole and fill with epoxy. Typical hole size is 1/2" larger than all thread.

Anchoring and Flashing Details

These are typical connections recommended by the Cast Stone Institute for similar applications. Consult your engineer for size and connection requirement before ordering anchors.

DETAIL 7-DOWEL PIN @ COPING

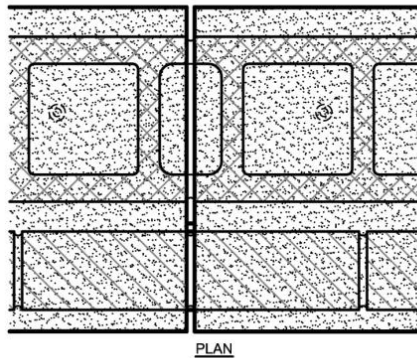
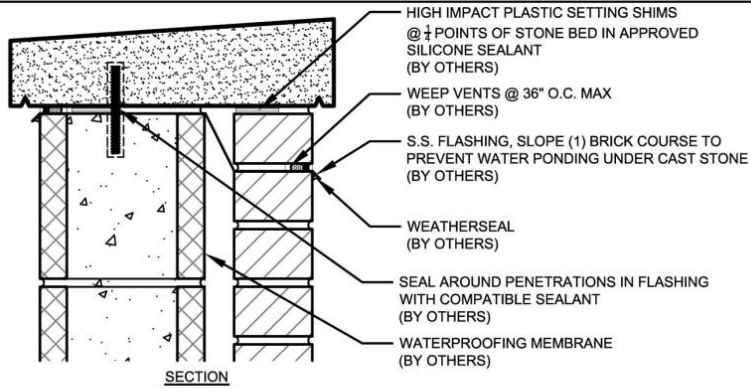
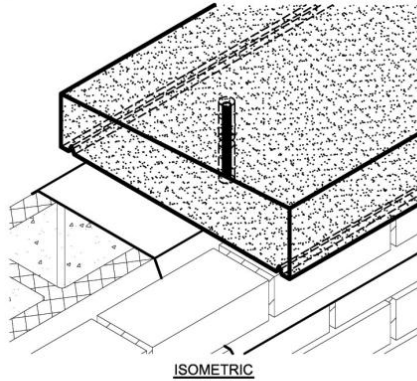

ALL THREAD PIN ISOMETRIC



Typical "A" dimensions are 2"-6", with the most common being 4"
Typical diameter varies from $\frac{3}{8}$ "-1" depending on the size of the stone. Most commonly used are $\frac{1}{2}$ " diameter x 4" LG. Field drill 1" diameter x 2" deep hole in to filled CMU and fill with non-shrink grout. Typical hole size is $\frac{1}{2}$ " larger than all thread.

DETAIL 8-FERRULE LOOP INSERT @ HEADER AND SOFFIT

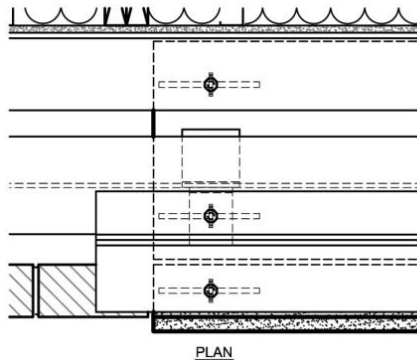
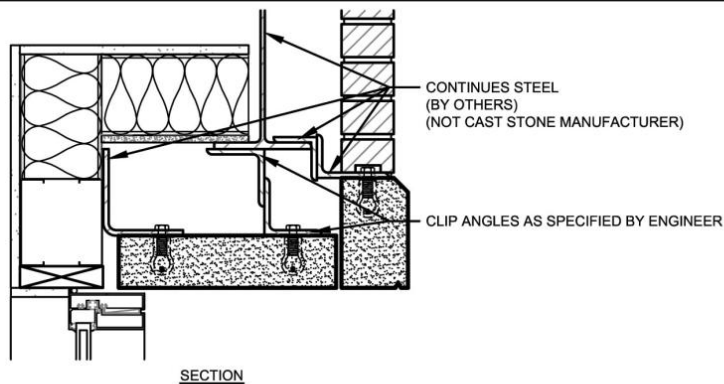
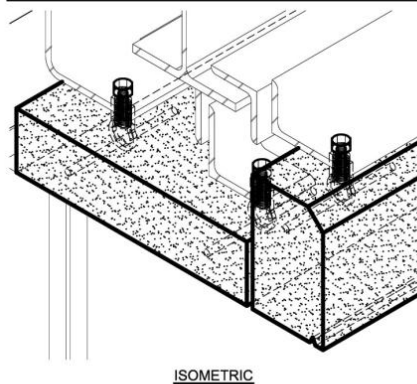

NC THREADED FERRULE LOOP INSERT ISOMETRIC

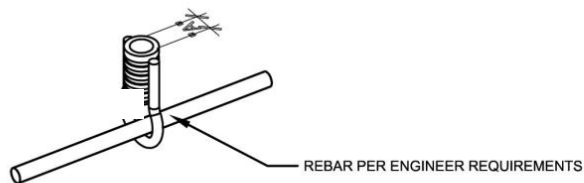

Typical "A" dimensions are $\frac{3}{8}$ "-1", with the most common being $\frac{1}{2}$ "

Anchoring and Flashing Details

These are typical connections recommended by the Cast Stone Institute for similar applications. Consult your engineer for size and connection requirement before ordering anchors.

DETAIL 9 - TYPICAL ANCHORAGE @ CORNICE

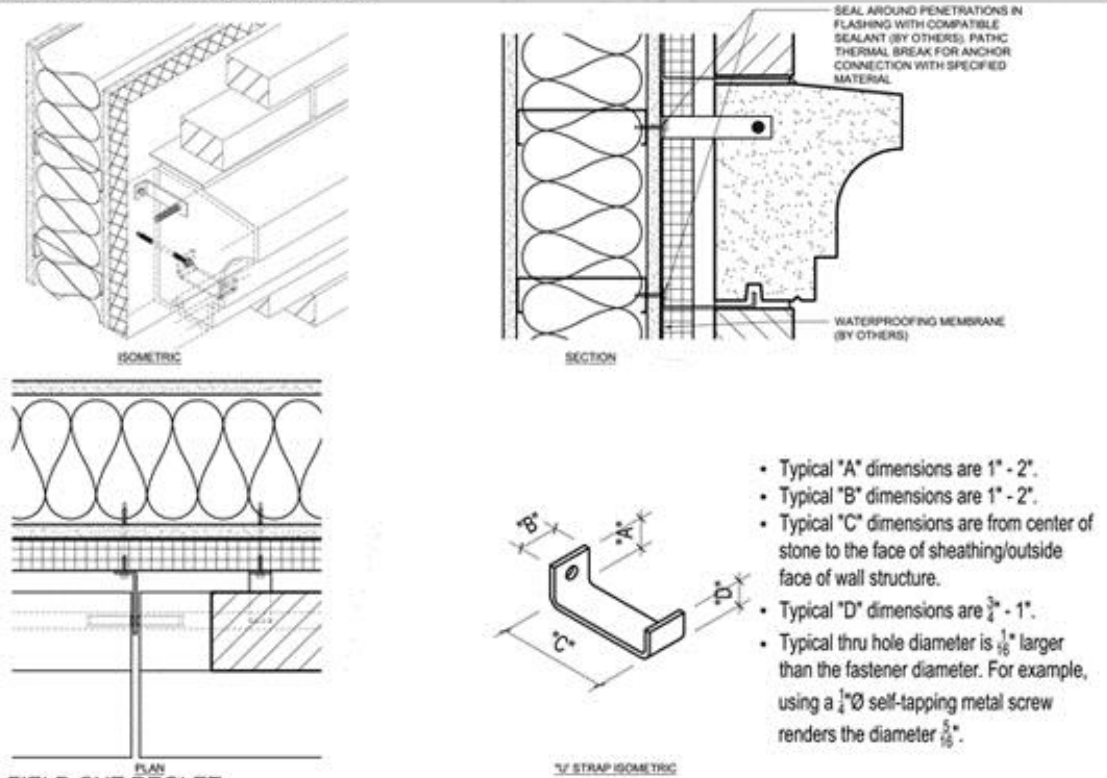

DETAIL 10 - FIELD CUT REGLET

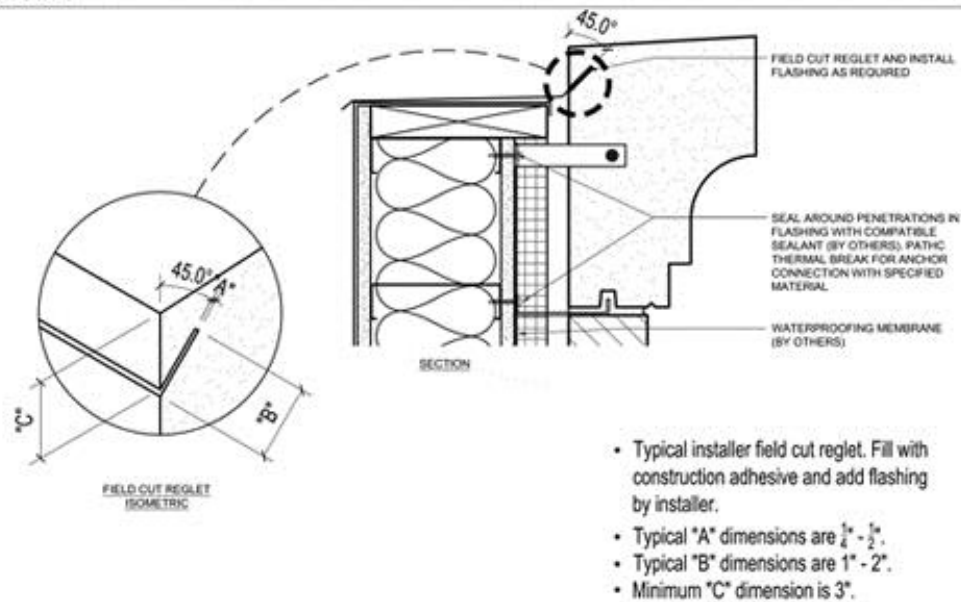



This Technical Bulletin addresses generally accepted practices, methods and general details for the use of Architectural Cast Stone. This document is designed *only as a guide* and is *not* intended for any specific application or project. It is the responsibility of design and construction professionals to determine the applicability and appropriate application of any detail to a specific project based on professional judgment, specific project conditions, manufacturer's recommendations and solid understanding of product characteristics. The Cast Stone Institute makes no express or implied warranty or guarantee of the techniques or construction methods identified herein. Technical references shall be made to the edition of the International Building Codes for the location of the structure, the latest edition of the TMS 402/406 Masonry Standards document and TMS 404, 504, 604 Standards for Design, Fabrication and Installation of Architectural Cast Stone.

The Cast Stone Institute (CSI) is a not-for-profit organization created to advance the design, manufacture and use of Architectural Cast Stone. To further this goal, the CSI continually disseminates information to targeted construction industry audiences through presentations, programs and technical publications.